

PS 3Y Precision Balances

Professional weighing under laboratory and slightly challenging industrial conditions



PS 3Y, d = 1 mg



PS 3Y, d = 0,01 g



Communication interfaces



PS 3Y.M, d = 0,01 g

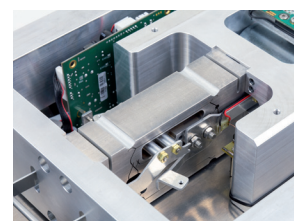

Radwag MonoBLOCK™, an innovative weighing system

Functions

- | | | | | |
|----------------|-----------------------|-----------------------------|---------------------|--------------------------------|
| Parts counting | Percent weighing | Statistical quality control | Under hook weighing | Ambient conditions measurement |
| Dosing | Statistics | Autotest | GLP procedures | Replaceable unit |
| Checkweighing | Animal weighing | Density determination | Proximity sensors | Multilingual menu |
| Formulations | Differential weighing | | | |

Features

RADWAG MonoBLOCK™, an Innovative Weighing System

The most advanced weighing system technology allowing measurement with the readability of $d=0.01$ g at 10 kg maximum capacity. The mechanism guarantees stable repeatability over the whole product life cycle, it also ensures high resistance to ambient conditions change.

Reliable Results and High Measurement Precision

Excellent measurement parameters and performance enable applying PS 3Y balances in laboratories and various branches of industry.

Weighing Heavy Loads with the Maximum Accuracy

Due to an exceptionally wide range of capacities it is possible to work with samples of different weight, from few grams to even over one hundred kilograms.

Remarkably Fast and Reliable Measurements

Powerful processor and modern design of the PS 3Y balances guarantee fast and reliable measurements and repeatability.

Intuitive Operation and Touch Screen

5.7" colour touch screen enables intuitive operation and easy access to numerous applications and functions of the weighing instrument.

Automatic Control of the Level

Levelling system facilitates adjustment of device level, it also uninterruptedly controls the level state, and informs about potential level deviations.

Automatic Adjustment

Internal adjustment system guarantees the highest accuracy and reliable measurements results.

Numerous Options of Data Management

The instrument enables saving all data of carried out measurements as reports and graphs.

Technical Specifications

	PS 200/2000.3Y	PS 250.3Y	PS 450.3Y	PS 600.3Y
Maximum capacity [Max]	200 g / 2000 g	250 g	450 g	600 g
Minimum load	0.02 g	0.02 g	0.02 g	0.02 g
Readability [d]	0.001 g / 0.01 g	0.001 g	0.001 g	0.001 g
Verification scale interval [e]	0.01 g / 0.1 g	0.01 g	0.01 g	0.01 g
Tare range	-2000 g	-250 g	-450 g	-600 g
Repeatability (5% Max)*	0.0005 / 0.005 g	0.0005 g	0.0005 g	0.0005 g
Repeatability (Max)	0.001 / 0.01	0.001 g	0.001 g	0.0015 g
Linearity	±0.002 g / ±0.01 g	±0.002 g	±0.002 g	±0.003 g
Sensitivity temperature drift**	$2 \times 10^{-6} / ^\circ\text{C} \times \text{Rt}$	$2 \times 10^{-6} / ^\circ\text{C} \times \text{Rt}$	$2 \times 10^{-6} / ^\circ\text{C} \times \text{Rt}$	$2 \times 10^{-6} / ^\circ\text{C} \times \text{Rt}$
Minimum weight (U=1%, k=2)	0.1 g	0.1 g	0.1 g	0.1 g
Minimum weight (USP)	1 g	1 g	1 g	1 g
Stabilization time	2 s	2 s	2 s	2 s
Adjustment	internal	internal	internal	internal
Verification	Yes	Yes	Yes	Yes
OIML Class	II	II	II	II
Indicator fastening	35 cm cable, wireless connection (option)***	35 cm cable, wireless connection (option)***	35 cm cable, wireless connection (option)***	35 cm cable, wireless connection (option)***
Display	5.7" colour, resistive touch screen	5.7" colour, resistive touch screen	5.7" colour, resistive touch screen	5.7" colour, resistive touch screen
Keypad	8 keys	8 keys	8 keys	8 keys
Protection class	IP 43	IP 43	IP 43	IP 43
Databases	19	19	19	19
Touch-free operation	2 programmable proximity sensors	2 programmable proximity sensors	2 programmable proximity sensors	2 programmable proximity sensors
USB-A	2	2	2	2
Ethernet	10 / 100 Mbit	10 / 100 Mbit	10 / 100 Mbit	10 / 100 Mbit
RS 232	2	2	2	2
Wireless connection	802.11 b/g/n	802.11 b/g/n	802.11 b/g/n	802.11 b/g/n
IN/OUT	4 × IN, 4 × OUT	4 × IN, 4 × OUT	4 × IN, 4 × OUT	4 × IN, 4 × OUT
Power supply	13.5 ÷ 16 V	13.5 ÷ 16 V	13.5 ÷ 16 V	13.5 ÷ 16 V
Power consumption	10 W	10 W	10 W	10 W
Operating temperature	+10 ÷ +40 °C	+10 ÷ +40 °C	+10 ÷ +40 °C	+10 ÷ +40 °C
Atmospheric humidity****	40 ÷ 80%	40 ÷ 80%	40 ÷ 80%	40 ÷ 80%
Transport and storage temperature	-20 ÷ +50 °C	-20 ÷ +50 °C	-20 ÷ +50 °C	-20 ÷ +50 °C
Weighing pan dimensions	128 × 128 mm	128 × 128 mm	128 × 128 mm	128 × 128 mm
Weighing device dimensions	425 × 251 × 168 mm	425 × 251 × 168 mm	425 × 251 × 168 mm	425 × 251 × 168 mm
Net weight	5.7 kg	5.3 kg	5.4 kg	5.7 kg
Gross weight	8.3 kg	7.8 kg	7.9 kg	8.3 kg
Packaging dimensions	720 × 360 × 260 mm	720 × 360 × 260 mm	720 × 360 × 260 mm	720 × 360 × 260 mm

Rt net weight

* repeatability is expressed as a standard deviation from 10 weighing cycles

** parameter determined in the following temperature range: +15 ÷ +35 °C

*** optional solution on purchase order

**** non-condensing conditions

In accordance with type approval, the balance parameters are maintained in temperature range: +15 ÷ +35 °C.

	PS 750.3Y	PS 1000.3Y	PS 1500.3Y	PS 2500.3Y
Maximum capacity [Max]	750 g	1000 g	1000 g	2500 g
Minimum load	0.02 g	0.02 g	0,5 g	0,5 g
Readability [d]	0.001 g	0.001 g	0,01 g	0,01 g
Verification scale interval [e]	0.01 g	0.01 g	0,1 g	0,1 g
Tare range	-750 g	-1000 g	-1500 g	-2500 g
Repeatability (5% Max)*	0.0005 g	0.0005 g	0,01 g	0,01 g
Repeatability (Max)	0.0015 g	0.0015 g	0,015 g	0,015 g
Linearity	±0.003 g	±0.003 g	±0,02 g	±0,02 g
Sensitivity temperature drift**	$2 \times 10^{-6} / ^\circ\text{C} \times \text{Rt}$	$2 \times 10^{-6} / ^\circ\text{C} \times \text{Rt}$	$2 \times 10^{-6} / ^\circ\text{C} \times \text{Rt}$	$2 \times 10^{-6} / ^\circ\text{C} \times \text{Rt}$
Minimum weight (U=1%, k=2)	0.1 g	0.1 g	1 g	1 g
Minimum weight (USP)	1 g	1 g	10 g	10 g
Stabilization time	2 s	2 s	1,5 s	1,5 s
Adjustment	internal	internal	internal	internal
Verification	Yes	Yes	Yes	Yes
OIML Class	II	II	II	II
Indicator fastening	35 cm cable, wireless connection (option)***	35 cm cable, wireless connection (option)***	35 cm cable, wireless connection (option)***	35 cm cable, wireless connection (option)***
Display	5.7" colour, resistive touch screen	5.7" colour, resistive touch screen	5.7" colour, resistive touch screen	5.7" colour, resistive touch screen
Keypad	8 keys	8 keys	8 keys	8 keys
Protection class	IP 43	IP 43	IP 43	IP 43
Databases	19	19	19	19
Touch-free operation	2 programmable proximity sensors	2 programmable proximity sensors	2 programmable proximity sensors	2 programmable proximity sensors
USB-A	2	2	2	2
Ethernet	10 / 100 Mbit	10 / 100 Mbit	10 / 100 Mbit	10 / 100 Mbit
RS 232	2	2	2	2
Wireless connection	802.11 b/g/n	802.11 b/g/n	802.11 b/g/n	802.11 b/g/n
IN/OUT	4 × IN, 4 × OUT	4 × IN, 4 × OUT	4 × IN, 4 × OUT	4 × IN, 4 × OUT
Power supply	13.5 ÷ 16 V	13.5 ÷ 16 V	13,5 ÷ 16 V	13,5 ÷ 16 V
Power consumption	10 W	10 W	10 W	10 W
Operating temperature	+10 ÷ +40 °C	+10 ÷ +40 °C	+10 ÷ +40 °C	+10 ÷ +40 °C
Atmospheric humidity****	40 ÷ 80%	40 ÷ 80%	40 ÷ 80%	40 ÷ 80%
Transport and storage temperature	-20 ÷ +50 °C	-20 ÷ +50 °C	-20 ÷ +50 °C	-20 ÷ +50 °C
Weighing pan dimensions	128 × 128 mm	128 × 128 mm	195 × 195 mm	195 × 195 mm
Weighing device dimensions	425 × 251 × 168 mm	425 × 251 × 168 mm	425 × 251 × 168 mm	425 × 251 × 168 mm
Net weight	5.7 kg	5.7 kg	5,3 kg	5,6 kg
Gross weight	8.3 kg	8.3 kg	7,9 kg	8,2 kg
Packaging dimensions	720 × 360 × 260 mm	720 × 360 × 260 mm	720 × 360 × 260 mm	720 × 360 × 260 mm

Rt net weight

* repeatability is expressed as a standard deviation from 10 weighing cycles

** parameter determined in the following temperature range: +15 ÷ +35 °C

*** optional solution on purchase order

**** non-condensing conditions

In accordance with type approval, the balance parameters are maintained in temperature range: +15 ÷ +35 °C.

PS 3000.3Y

Maximum capacity [Max]	3000 g
Minimum load	0.02 g
Readability [d]	0.001 g
Verification scale interval [e]	—
Tare range	–3000 g
Repeatability (5% Max)*	0.0005 g
Repeatability (Max)	0.0015 g
Linearity	±0.004 g
Sensitivity temperature drift**	$2 \times 10^{-6} / ^\circ\text{C} \times R_t$
Minimum weight (U=1%, k=2)	0.1 g
Minimum weight (USP)	1 g
Stabilization time	3 s
Adjustment	internal
Verification	—
OIML Class	—
Indicator fastening	35 cm cable, wireless connection (option)***
Display	5.7" colour, resistive touch screen
Keypad	8 keys
Protection class	IP 43
Databases	19
Touch-free operation	2 programmable proximity sensors
USB-A	2
Ethernet	10 / 100 Mbit
RS 232	2
Wireless connection	802.11 b/g/n
IN/OUT	4 × IN, 4 × OUT
Power supply	13.5 ÷ 16 V
Power consumption	10 W
Operating temperature	+10 ÷ +40 °C
Atmospheric humidity****	40 ÷ 80%
Transport and storage temperature	–20 ÷ +50 °C
Weighing pan dimensions	128 × 128 mm
Weighing device dimensions	425 × 251 × 168 mm
Net weight	5.7 kg
Gross weight	8.3 kg
Packaging dimensions	720 × 360 × 260 mm

- Rt net weight
 * repeatability is expressed as a standard deviation from 10 weighing cycles
 ** parameter determined in the following temperature range: +15 ÷ +35 °C
 *** optional solution on purchase order
 **** non-condensing conditions

In accordance with type approval, the balance parameters are maintained in temperature range: +15 ÷ +35 °C.

	PS 4500.3Y.M	PS 6100.3Y.M	PS 8100.3Y.M	PS 10100.3Y.M
Maximum capacity [Max]	4500 g	6100 g	8100 g	10100 g
Minimum load	0.5 g	0.5 g	0.5 g	0.5 g
Readability [d]	0.01 g	0.01 g	0.01 g	0.01 g
Verification scale interval [e]	—	—	—	—
Tare range	-4500 g	-6100 g	-8100 g	-10100 g
Repeatability (5% Max)*	0.005 g	0.005 g	0.005 g	0.005 g
Repeatability (Max)	0.008 g	0.008 g	0.01 g	0.012 g
Linearity	±0.03 g	±0.03 g	±0.03 g	±0.03 g
Sensitivity temperature drift**	$2 \times 10^{-6} / ^\circ\text{C} \times R_t$	$2 \times 10^{-6} / ^\circ\text{C} \times R_t$	$2 \times 10^{-6} / ^\circ\text{C} \times R_t$	$2 \times 10^{-6} / ^\circ\text{C} \times R_t$
Minimum weight (U=1%, k=2)	1 g	1 g	1 g	1 g
Minimum weight (USP)	10 g	10 g	10 g	10 g
Stabilization time	1.5 s	1.5 s	1.5 s	1.5 s
Adjustment	internal	internal	internal	internal
Verification	Yes	Yes	Yes	—
OIML Class	II	II	II	—
Indicator fastening	35 cm cable, wireless connection (option)***	35 cm cable, wireless connection (option)***	35 cm cable, wireless connection (option)***	35 cm cable, wireless connection (option)***
Display	5.7" colour, resistive touch screen	5.7" colour, resistive touch screen	5.7" colour, resistive touch screen	5.7" colour, resistive touch screen
Keypad	8 keys	8 keys	8 keys	8 keys
Protection class	IP 43	IP 43	IP 43	IP 43
Databases	19	19	19	19
Touch-free operation	2 programmable proximity sensors	2 programmable proximity sensors	2 programmable proximity sensors	2 programmable proximity sensors
USB-A	2	2	2	2
Ethernet	10 / 100 Mbit	10 / 100 Mbit	10 / 100 Mbit	10 / 100 Mbit
RS 232	2	2	2	2
Wireless Connection	802.11 b/g/n	802.11 b/g/n	802.11 b/g/n	802.11 b/g/n
IN/OUT	4 × IN, 4 × OUT	4 × IN, 4 × OUT	4 × IN, 4 × OUT	4 × IN, 4 × OUT
Power supply	13.5 ÷ 16 V	13.5 ÷ 16 V	13.5 ÷ 16 V	13.5 ÷ 16 V
Power consumption	10 W	10 W	10 W	10 W
Operating temperature	+10 ÷ +40 °C	+10 ÷ +40 °C	+10 ÷ +40 °C	+10 ÷ +40 °C
Atmospheric humidity****	40 ÷ 80%	40 ÷ 80 %	40 ÷ 80 %	40 ÷ 80 %
Transport and storage temperature	-20 ÷ +50 °C	-20 ÷ +50 °C	-20 ÷ +50 °C	-20 ÷ +50 °C
Weighing pan dimensions	195 × 195 mm	195 × 195 mm	195 × 195 mm	195 × 195 mm
Weighing device dimensions	425 × 251 × 99 mm	425 × 251 × 101 mm	425 × 251 × 101 mm	425 × 251 × 101 mm
Net weight	5.6 kg	6.8 kg	6.8 kg	6.8 kg
Gross weight	8.2 kg	9.4kg	9.4kg	9.4kg
Packaging dimensions	720 × 360 × 260 mm	720 × 360 × 260 mm	720 × 360 × 260 mm	720 × 360 × 260 mm

Rt net weight

* repeatability is expressed as a standard deviation from 10 weighing cycles

** parameter determined in the following temperature range: +15 ÷ +35 °C

*** optional solution on purchase order

**** non-condensing conditions

In accordance with type approval, the balance parameters are maintained in temperature range: +15 ÷ +35 °C.

Dimensions

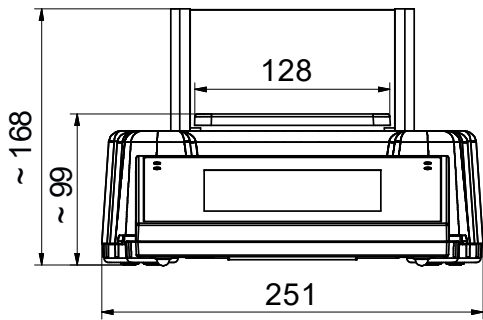

PS 3Y, d = 0.001 g

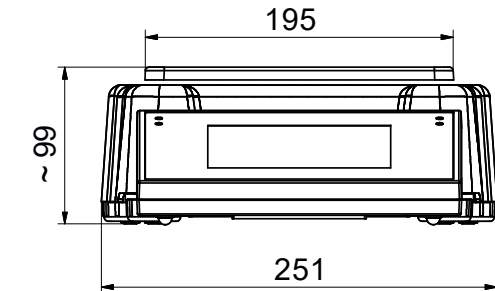
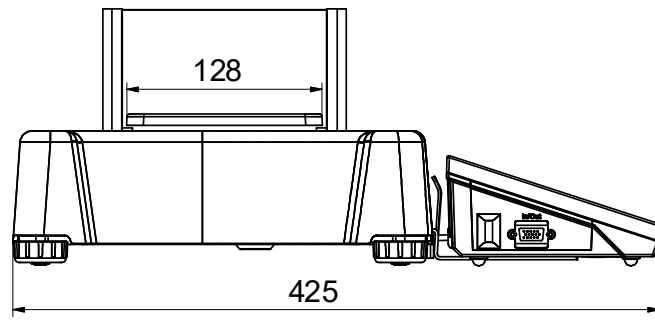

PS 3Y, d = 0.01 g

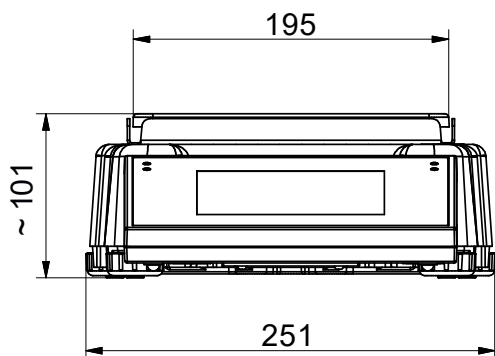
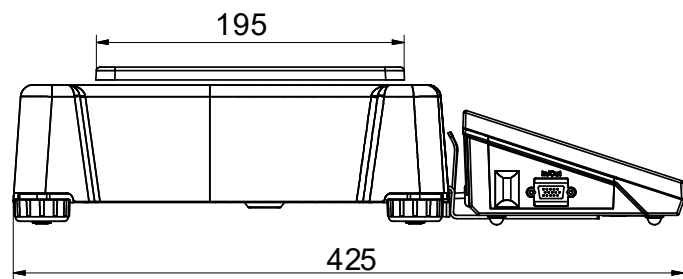

PS 3Y.M, d = 0.01 g

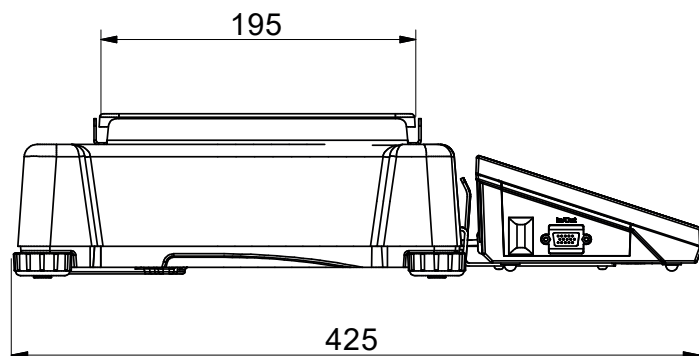

Accessories

Weighing Tables

- granite antivibration table
- antivibration tables for laboratory balances
- professional weighing table

Professional Weighing

- KIT 128 density determination kit
- KIT 195 density determination kit
- KIT 195.M density determination kit
- under-hook weighing rack

Ambient Conditions

- THB-S or THB-P sensor

Peripheral Devices

- label printer
- receipt printer
- Epson dot matrix printer
- barcode scanners
- PA-04/H automatic feeder
- WD-5/3Y LCD display

Cables, Converters

- P0108: RS 232 cable (balance-computer)
- P0167: RS 232 cable (balance-computer)
- P0151: RS 232 cable (balance - EPSON printer)

Electrical Accessories

- ZR-02 power supply with battery

Draft Shields and Anti-Draft Chambers

- draft shield with a weighing pan 128 x 128 mm
- protective cover indicator

Remaining Accessories

- suitcase for PS

Dedicated Software

R-LAB

- collecting measurements
- carrying out statistical analysis of measurements
- customized graphs and reports

E2R PGC

- synchronization of databases, operators, products schedules
- record of measurements and PGC controls carried out on weighing instruments linked in ETHERNET network
- quality assessment of pre- packaged goods based on acquired data

E2R Weighing Records

- complete, automated databases synchronization
- fully supported processes of labelling and parts counting
- record of weighings, weighings archiving
- basic and advanced (with graphs) reports

Label Editor R02

- designing label templates
- sending graphics and fonts to label printers
- printing label templates using connected printers

Audit Trail Reader

- support of Audit Trail function available for 3Y, 4Y, HY10, WLY, WPY series weighing instruments
- record of operator's activity from the moment of logging in

RAD KEY

- Establishing cooperation between a weighing instrument and a computer

R. Barcode

- The basic function software is presentation of the data sent by barcode scanners connected to PC via USB or RS232

3Y Database Editor

- databases readout
- databases editing
- databases saving - from computer software to connected weighing instrument
- connection with 3Y balances via Ethernet and RS232

Radwag Development Studio

- presentation of functions (and subfunctions) of communication protocol (Common Communication Protocol)
- possibility of connection with weighing equipment on which each function is carried out,
- library with mass control, contained within the development environment
- complete documentation of the communication protocol
- set of user manuals for different solutions addressed for programmers employed in companies using RADWAG-manufactured weighing equipment

LabView Driver

- operation of RADWAG balances in LabView environment

RADWAG Connect

- establishing communication with all balances, scales and weighing modules using Common Communication Protocol
- communication via local network,
- support of basic functions
- auto searching for devices
- connecting with few devices simultaneously, swapping between them
- clear list of connected platforms
- record of measurements in the program,
- export of carried out measurements to CSV file,
- work performed using freely selected device with Windows 10 operating system

RADWAG Remote Desktop

- remote operation via computer, mobile phone or tablet
- sending text messages
- version for Windows 10 and Android systems

Parameters Editor

- remote change of parameters
- remote on-line preview of the display
- displaying current mass indication
- software update
- file loading, editing and saving parameters to a file
- import and export of parameters
- interfaces: RS232, Ethernet and Wireless Connection.
- quick and easy edition of balance parameters using computer.